

a

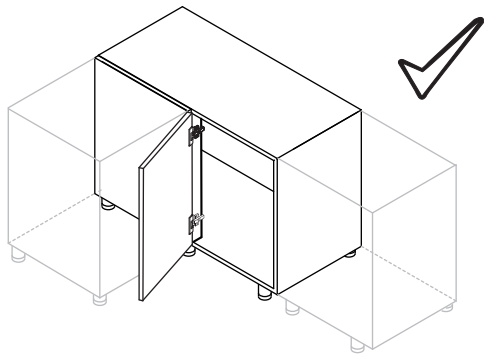

b

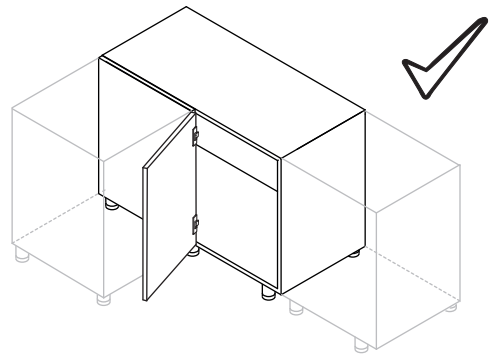

1.a

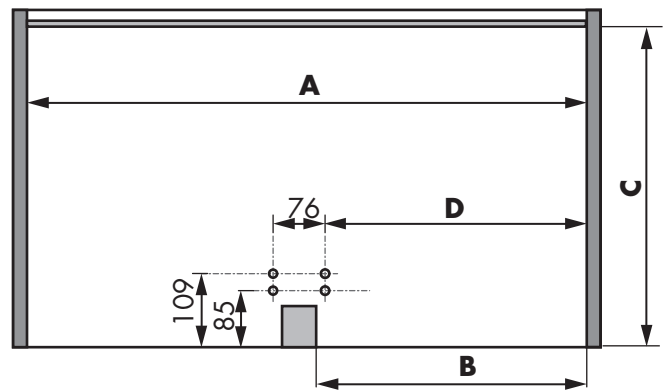
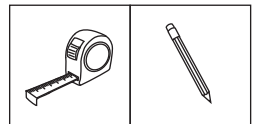
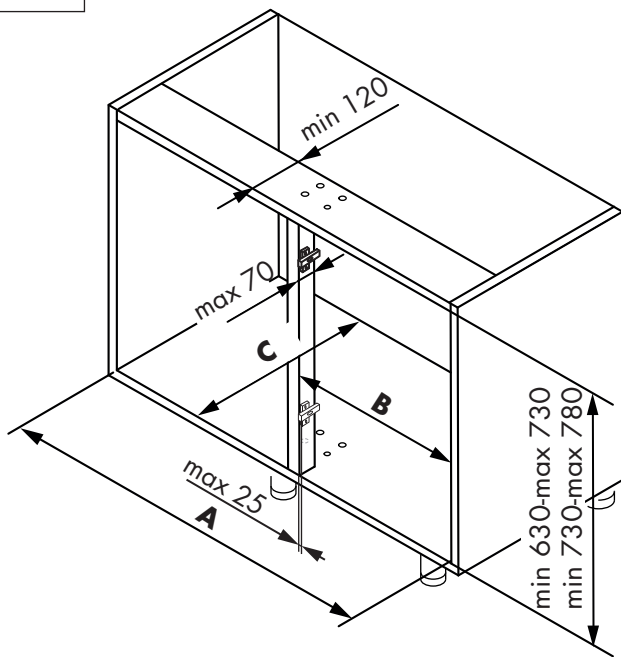

	A	B	C	D
ø750	min 765	min 415	min 485	350
ø850	min 865	min 465	min 535	400

Unidades en milímetros | Units in millimeters | Unités en millimètres

1.b

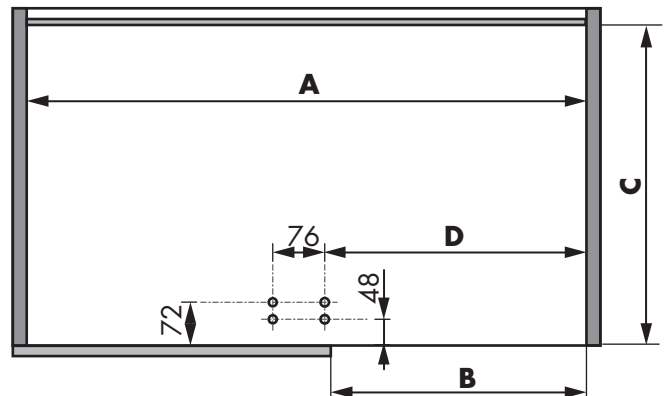
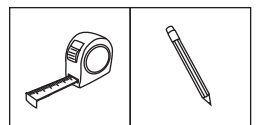
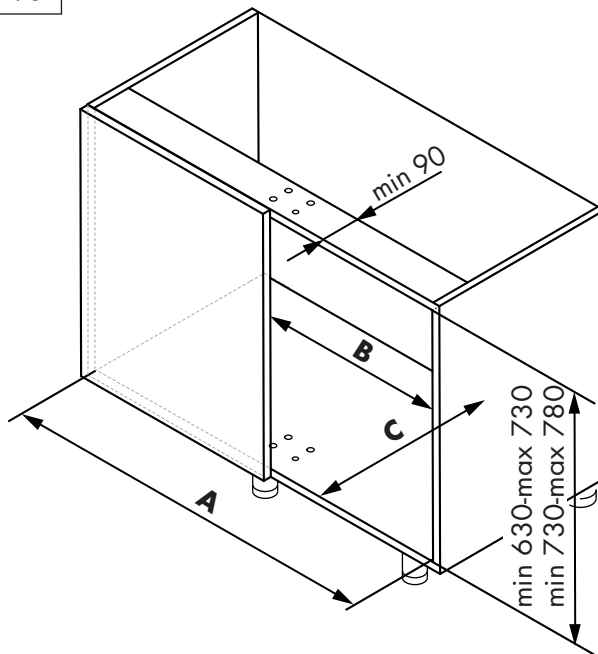

	A	B	C	D
ø750	min 765	min 415	min 450	350
ø850	min 865	min 465	min 500	400

Unidades en milímetros | Units in millimeters | Unités en millimètres

2

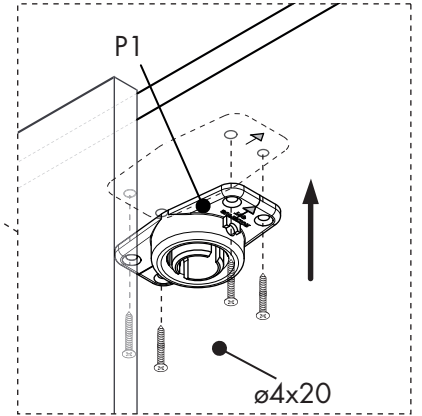
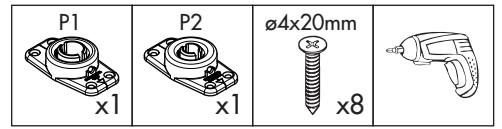
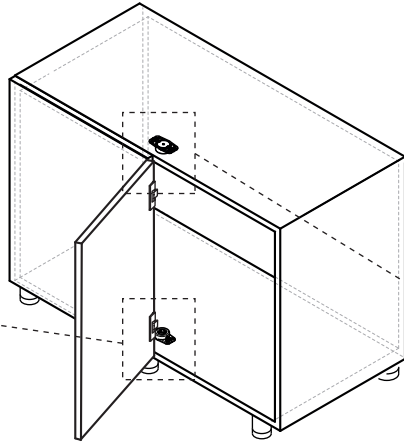
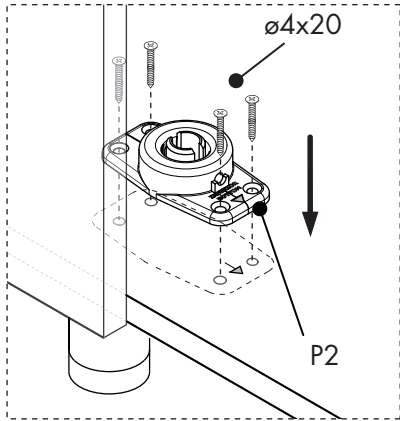

3

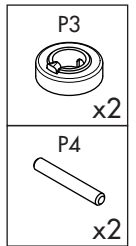
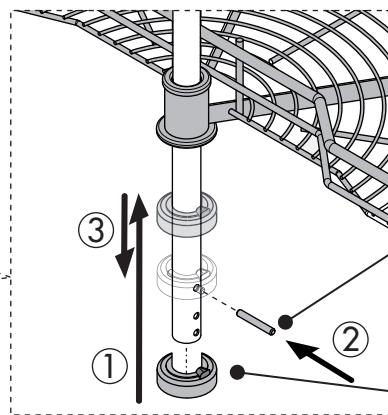
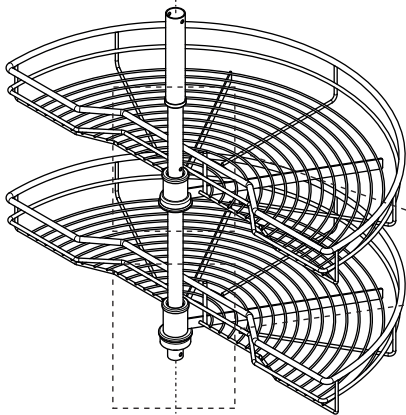

4

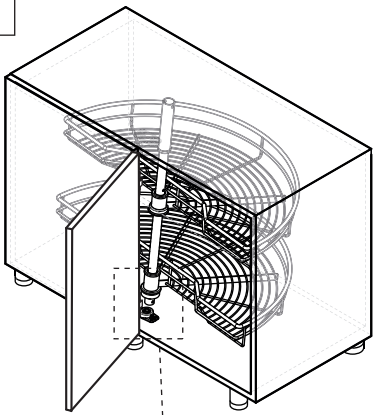

5

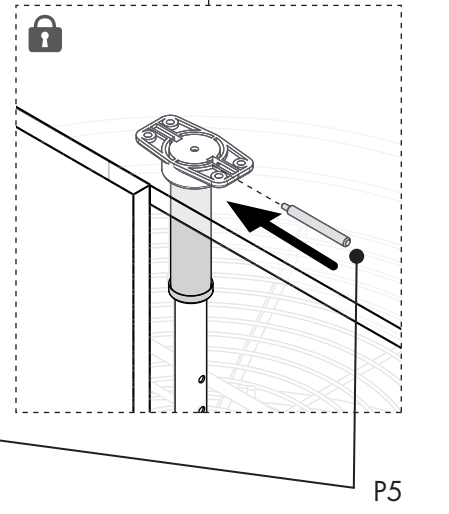
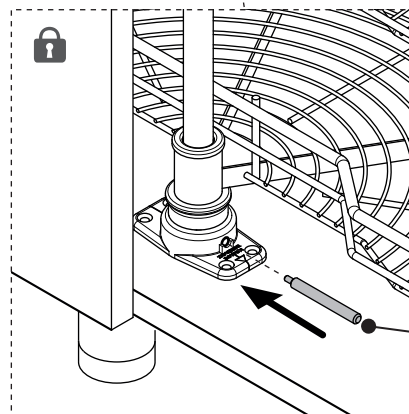
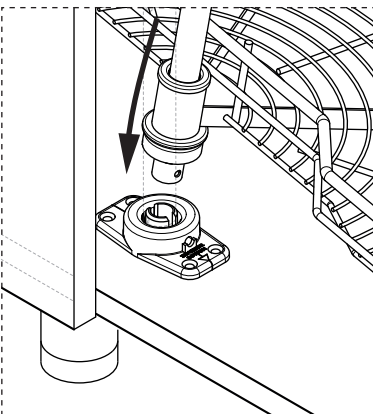
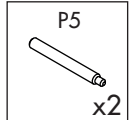
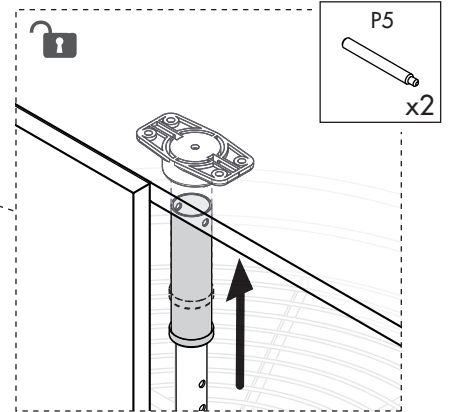
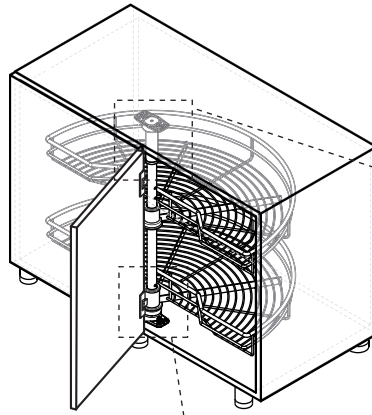

6

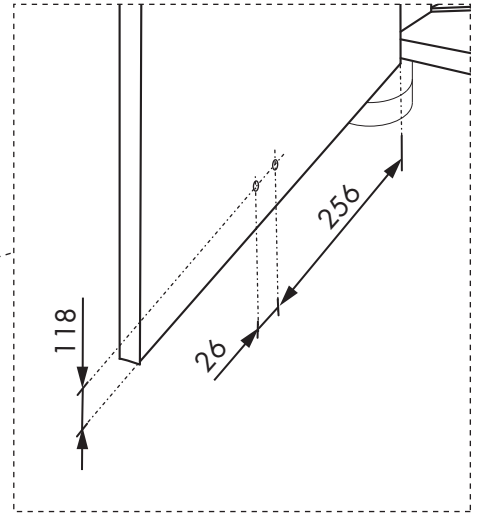
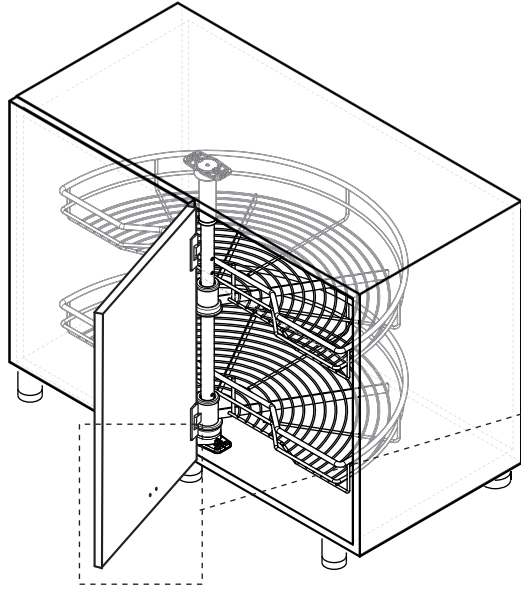
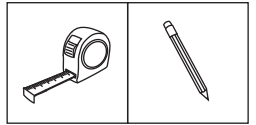

Unidades en milímetros | Units in millimeters | Unités en millimètres

7

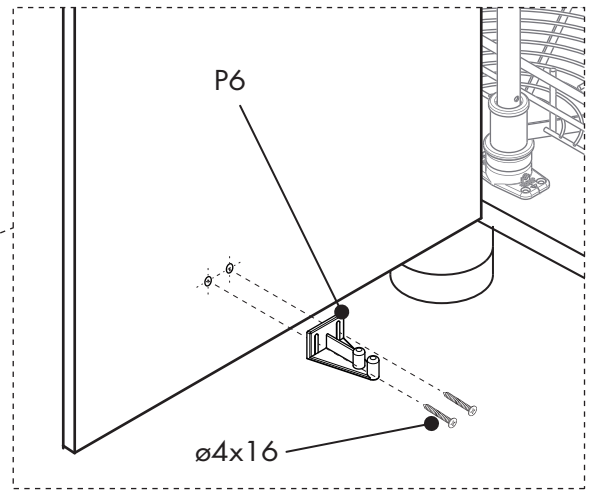
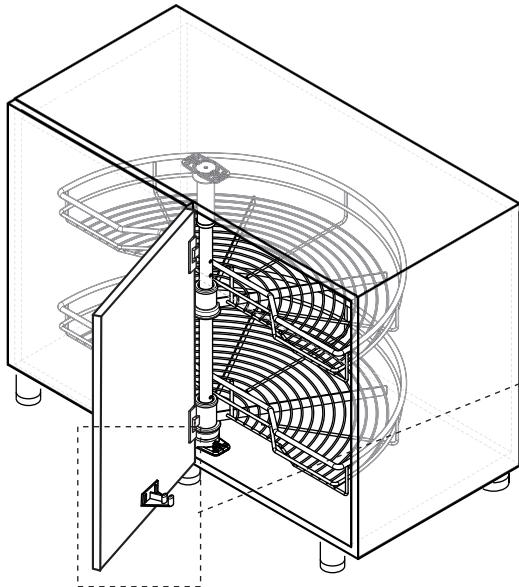

8

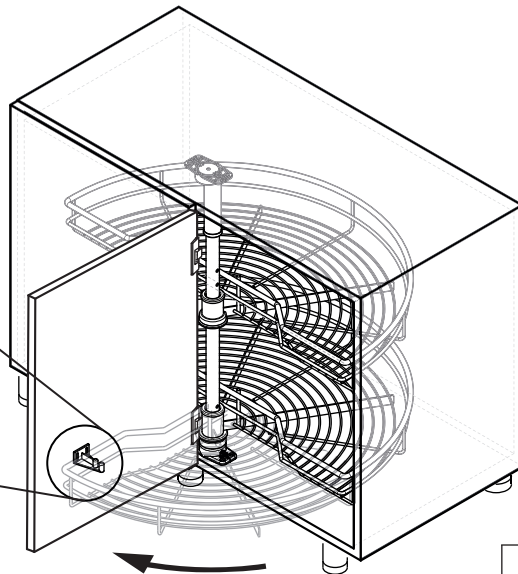
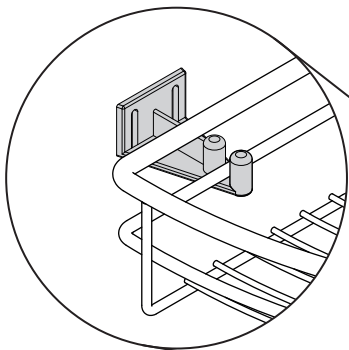

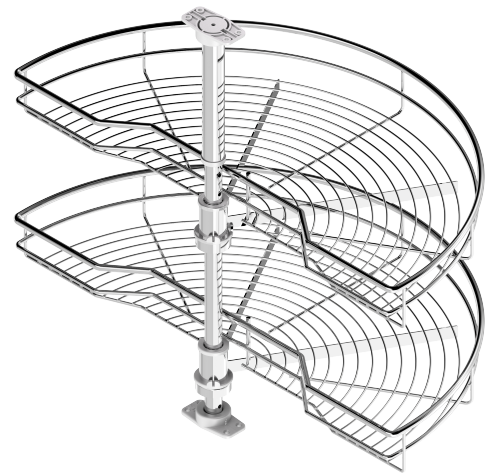
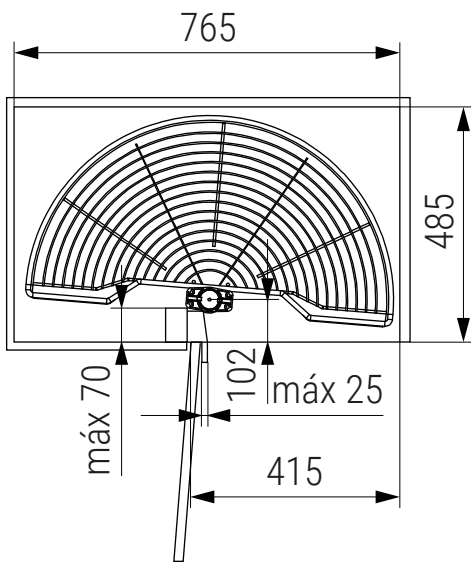
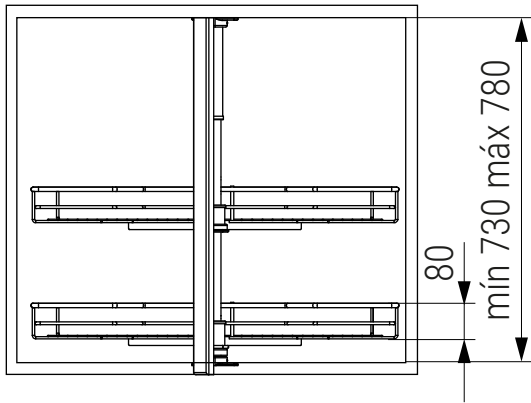

	NOMBRE	FIRMA	FECHA	DESCRIPCIÓN: Bandeja giro 180° CINTIA Ø750 Con Tubo + accesorios Regulable H730-780mm.
DIBUJ.	AG		04/10/2022	
VERIF.	AG			
APROB.				
FABR.				
CALID.				Unidades envase: 1 unidad
				Unidades embalaje: 1 unidad

Contigo desde 1893

Verdú®

Código	Material	Acabado	Ø	Peso		
1008.152	acero	Cromado	750	0,52kg		A4

www.verdustore.com

ESCALA:1:20

HOJA 1 DE 1